

All Seasons Tent Sales

10 x 10 Frame Tent Set Up Instructions

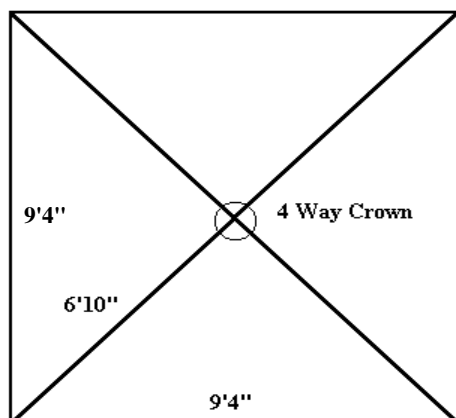

Corner

Pipe			
QTY	SIZE	COLOR	Style
4	9' 4"	White	Spreader
4	6' 10"	Blue	Hip Rafter
4	7' 8"	Black	Legs



4 Way Crown



Corner

Components	
QTY	Style
1	4 - Way Crown
4	Regular Corners
4	Weights / Stakes
4	Ropes
20	Tent Pins
Optional Items	
1	Brace Package
4	Ratchets
4	Baseplates

Pre-Site Inspection- Call your local utility companies prior to installation for any underground obstructions.

1. Layout the frame parts in the estimated location pertaining to the diagram. The spreader pipe is placed out to form the perimeter, and the rafters are laid in the interior location.

2. Start with the 4 way crown. Attach the hip rafter (6'10" blue) to the 4 way crown by sliding the poles in or over the fitting (depending if you have 1" or 2" Pipe) and lining up the holes in the pole with those in the fitting. Place a pin in the first hole to secure the pole in place.

3. Attach the corner fitting to the hip rafter by sliding the pole over the fitting. Line up the hole of the pole with those of the fitting and place a pin.

4. The perimeter is ready for assembly. Connect the corners to the corners using the spreaders (9'4" white). Slide the poles over the fittings, line up the holes, and pin the pole and fitting together. When all of the spreaders have been secured in place, the frame will be complete.

5. Place the tent top over the frame, by spreading the tent out on one end and flapping the tent top while pulling it over the top. This, flapping, will make it easier to go over the frame and prevents any snags.

6. Secure the tent top to the frame by securing the straps on the inside of the tent at each corner location.

7. Start at one corner and manually raise the frame so that the leg (7'8" black) can slide in or over the corner fitting. Pin the leg to the fitting. (When raising the tent, raise INTO the wind)

8. Proceed to work your way around the tent putting one leg in at a time until all legs are standing and pinned.

9. Now that the frame tent is erected, fasten the rest of tent top completely to the frame, using the straps on the inside of the tent. Make sure that all of the straps are tight and that the tent top is sitting evenly over the frame.

10. Drive a stake about four feet out from each leg and tie off the rope or ratchet to each leg.

Your tent installation is now complete.

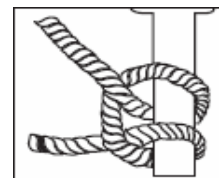
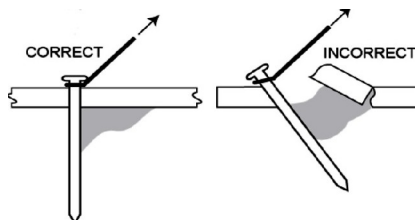

All Seasons Tent Sales

12 x 12 Frame Tent Set Up Instructions

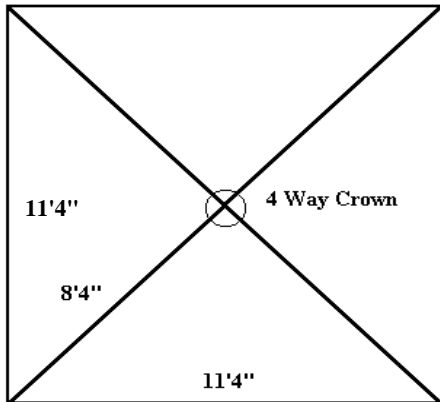

Corner

Pipe			
QTY	SIZE	COLOR	Style
4	11' 4"	Blue/White	Spreader
4	8' 4"	Yellow	Hip Rafter
4	7' 8"	Black	Legs



4 Way Crown



Corner

Components	
QTY	Style
1	4 - Way Crown
4	Regular Corners
4	Weights / Stakes
4	Ropes
20	Tent Pins
Optional Items	
1	Brace Package
4	Ratchets
4	Baseplates

Pre-Site Inspection- Call your local utility companies prior to installation for any underground obstructions.

1. Layout the frame parts in the estimated location pertaining to the diagram. The spreader pipe is placed out to form the perimeter, and the rafters are laid in the interior location.
2. Start with the 4 way crown. Attach the hip rafter (8' 4" yellow) to the 4 way crown by sliding the poles in or over the fitting (depending if you have 1" or 2" Pipe) and lining up the holes in the pole with those in the fitting. Place a pin in the first hole to secure the pole in place.
3. Attach the corner fitting to the hip rafter by sliding the pole over the fitting. Line up the hole of the pole with those of the fitting and place a pin.
4. The perimeter is ready for assembly. Connect the corners to the corners using the spreaders (11' 4" blue/white). Slide the poles over the fittings, line up the holes, and pin the pole and fitting together. When all of the spreaders have been secured in place, the frame will be complete.
5. Place the tent top over the frame, by spreading the tent out on one end and flapping the tent top while pulling it over the top. This, flapping, will make it easier to go over the frame and prevents any snags.
6. Secure the tent top to the frame by securing the straps on the inside of the tent at each corner location.
7. Start at one corner and manually raise the frame so that the leg (7'8" black) can slide in or over the corner fitting. Pin the leg to the fitting. (When raising the tent, raise INTO the wind)
8. Proceed to work your way around the tent putting one leg in at a time until all legs are standing and pinned.
9. Now that the frame tent is erected, fasten the rest of tent top completely to the frame, using the straps on the inside of the tent. Make sure that all of the straps are tight and that the tent top is sitting evenly over the frame.
10. Drive a stake about four feet out from each leg and tie off the rope or ratchet to each leg.

Your tent installation is now complete.

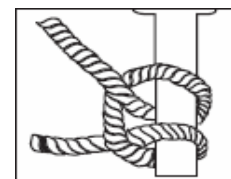
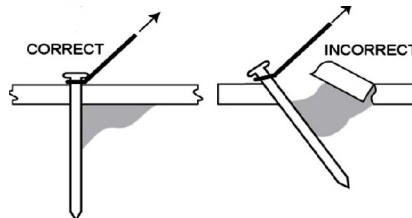

All Seasons Tent Sales

15 x 15 Frame Tent Set Up Instructions

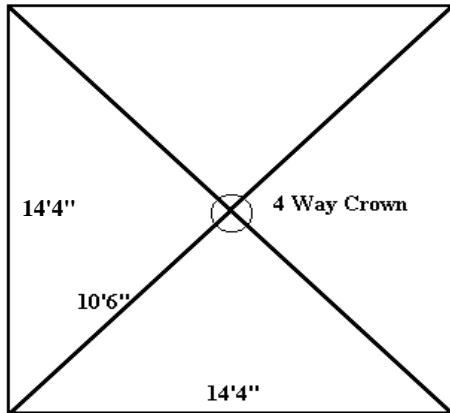

Corner

Pipe			
QTY	SIZE	COLOR	Style
4	14' 4"	Red	Spreader
4	10' 6"	Green	Hip Rafter
4	7' 8"	Black	Legs



4 Way Crown



Corner

Components	
QTY	Style
1	4 - Way Crown
4	Regular Corners
4	Weights / Stakes
4	Ropes
20	Tent Pins
Optional Items	
1	Brace Package
4	Ratchets
4	Baseplates

Pre-Site Inspection- Call your local utility companies prior to installation for any underground obstructions.

1. Layout the frame parts in the estimated location pertaining to the diagram. The spreader pipe is placed out to form the perimeter, and the rafters are laid in the interior location.

2. Start with the 4 way crown. Attach the hip rafter (10' 6" green) to the 4 way crown by sliding the pole in or over the fitting (depending if you have 1" or 2" Pipe) and lining up the holes in the pole with those in the fitting. Place a pin in the first hole to secure the pole in place.

3. Attach the corner fitting to the hip rafter by sliding the pole over the fitting. Line up the hole of the pole with those of the fitting and place a pin.

4. The perimeter is ready for assembly. Connect the corners to the corners using the spreaders (14' 4" red). Slide the poles over the fittings, line up the holes, and pin the pole and fitting together. When all of the spreaders have been secured in place, the frame will be complete.

5. Place the tent top over the frame, by spreading the tent out on one end and flapping the tent top while pulling it over the top. This, flapping, will make it easier to go over the frame and prevents any snags.

6. Secure the tent top to the frame by securing the straps on the inside of the tent at each corner location.

7. Start at one corner and manually raise the frame so that the leg (7'8" black) can slide in or over the corner fitting. Pin the leg to the fitting. (When raising the tent, raise INTO the wind)

8. Proceed to work your way around the tent putting one leg in at a time until all legs are standing and pinned.

9. Now that the frame tent is erected, fasten the rest of tent top completely to the frame, using the straps on the inside of the tent. Make sure that all of the straps are tight and that the tent top is sitting evenly over the frame.

10. Drive a stake about four feet out from each leg and tie off the rope or ratchet to each leg.

Your tent installation is now complete.

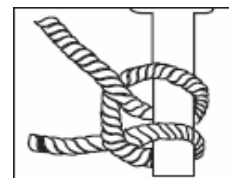
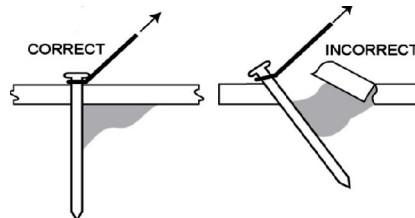

All Seasons Tent Sales

20 x 20 Frame Tent Set Up Instructions

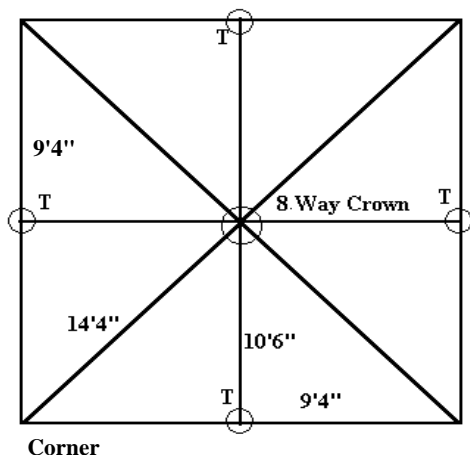

Pipe			
QTY	SIZE	COLOR	Style
4	14' 4"	Red	Hip Rafter
4	10' 6"	Green	Rafter
8	9'4"	White	Spreader
8	7' 8"	Black	Legs



8 Way Crown



Regular T



Corner

Components	
QTY	Style
1	8 - Way Crown
4	Regular Corners
4	Regular T's
8	Weights / Stakes
8	Ropes
40	Tent Pins
Optional Items	
1	Brace Package
8	Ratchets
8	Baseplates

Pre-Site Inspection- Call your local utility companies prior to installation for any underground obstructions.

1. Layout the frame parts in the estimated location pertaining to the diagram. The spreader pipe is placed out to form the perimeter, and the rafters are laid in the interior location.
2. Start with the 8 way crown. Lay the crown on a flat surface to determine the correct placement, when the crown is on a flat surface the angles that are not touching the ground (every other one) will correlate with the 4 corners. Attach the hip rafters (14'4" red) to the 8 way crown at the angles, that do not touch the ground, by sliding the pole in or over the fitting and lining up the holes in the pole with those in the fitting. Place a pin in the first hole to secure the pole in place. Repeat at all four corners.
3. Attach the poles (10'6" green) to the remaining angles of the 8 way crown using the same technique as in step 2.
4. Connect the corner fitting to the hip rafter by sliding the pole in or over the fitting. Line up the hole of the pole with those of the fitting and place a pin.
5. Join the Regular T fitting to the rafters by sliding the pole over the fitting. Line up the hole of the pole with those of the fitting and place a pin.
6. The perimeter is ready for assembly. Connect the Regular T to the corners using the spreaders (9'4" white). Slide the poles over the fittings, line up the holes, and pin the pole and fitting together. When all of the spreaders have been secured in place, the frame will be complete.

OMIT next step if 1 Piece Top

Lace the tent together: A) Line up the two crown patches in the middle of the tent section (the lace end will always be on the bottom). Starting in the middle and working out, B) Pull the first lace up through the first small grommet. C) Pull the second lace through the second grommet. D) Pull the second lace through the first lace's loop. E) Pull the third lace through third grommet. F) Pull the third lace through the second lace's loop. Repeat steps B through F down the lace line of the tent until the third grommet from the edge of the tent is reached, the third lace should be twice as long as all of the other loops (referred to as double loop). When the tent is laced down to the third grommet (the double loop), pull the remaining 2 laces through the remaining 2 grommets. Loop the second lace from the tent perimeter into the first lace (the lace is now going towards the direction of the double loop). Pull the third

lace (double loop) through the second loop. The third lace (double loop) should now be strung through 2 loops (the second loop and the fourth loop). Tie-off the double loop with the fourth lace so the loops can not come loose. Note: This does not in anyway affect the strength of the tent; it holds the tent sections together. A simple double knot is effective. After lacing each section, you will need to fasten down the rain flap that covers the lace line by clipping the spring clips onto the rain flap closer rope.

7. Place the tent top over the frame, by spreading the tent out on one end and flapping the tent top while pulling it over the top. This, flapping, will make it easier to go over the frame and prevents any snags.

8. Secure the tent top to the frame by fastening the straps on the inside of the tent at each corner location.

9. Start at one corner and manually lift the frame so that the leg (7'8" black) can slide over the corner fitting. Pin the leg to the fitting. (When raising the tent, raise INTO the wind)

10. Proceed to work your way around the tent putting one leg in at a time until all legs are standing and pinned.

11. Now that the frame tent is erected, fasten the rest of tent top completely to the frame, using the straps on the inside of the tent. Make sure that all of the straps are tight and that the tent top is sitting evenly over the frame.

12. Drive a stake about four feet out from each leg and tie off the rope or ratchet to each leg.

Your tent installation is now complete.

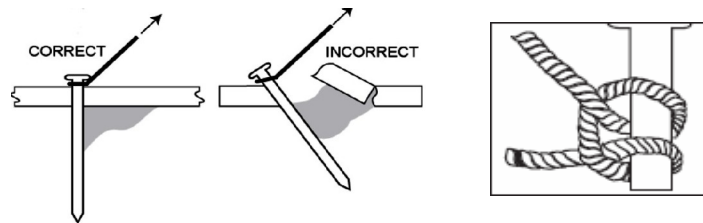

All Seasons Tent Sales

20 x 30 Frame Tent Set Up Instructions

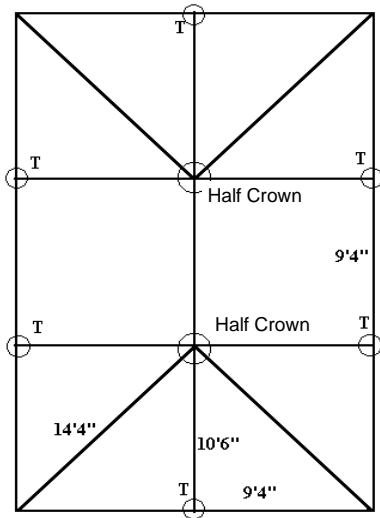

Corner

Pipe			
QTY	SIZE	COLOR	Style
4	14' 4"	Red	Hip Rafter
6	10' 6"	Green	Rafter
11	9'4"	White	Spreader
10	7' 8"	Black	Legs



Half Crown



Regular T



Corner

Components	
QTY	Style
2	Half Crown
4	Regular Corners
6	Regular T's
10	Weights / Stakes
10	Ropes
52	Tent Pins
Optional Items	
1	Brace Package
10	Ratchets
10	Baseplates

Pre-Site Inspection- Call your local utility companies prior to installation for any underground obstructions.

1. Layout the frame parts in the estimated location pertaining to the diagram. The spreader pipe is placed out to form the perimeter, and the rafters are laid in the interior location.
2. Start with one of the Half Crowns. Attach the hip rafters (14'4" red) to the Half Crown at the second and fourth points by sliding the pole over the fitting and lining up the holes in the pole with those in the fitting. Place a pin in the first hole to secure the pole in place.
3. Attach the Rafter poles (10'6" green) to the remaining points - one, three, and five of the Half Crown using the same technique as in step 2.
4. Attach a spreader (9'4" white) to the Half Crown, and connect it to the other Half Crown.
5. Connect the corner fittings to the hip rafter by sliding the pole over the fitting. Line up the hole of the pole with the first hole of the fitting and place a pin.
6. Join the regular t fittings to the poles by sliding the pole over the fitting. Line up the hole of the pole with the first hole of the fittings and place a pin.
7. The perimeter is ready for assembly. Connect the Regular T to the corners using the spreaders (9'4" white). Slide the poles over the fittings, line up the holes, and pin the pole and fitting together. When all of the spreaders have been secured in place, the frame will be complete.

OMIT next step if 1 Piece Top

8. Lace the tent together: A) Line up the two crown patches in the middle of the tent section (the lace end will always be on the bottom). Starting in the middle and working out, B) Pull the first lace up through the first small grommet. C) Pull the second lace through the second grommet. D) Pull the second lace through the first lace's loop. E) Pull the third lace through third grommet. F) Pull the third lace through the second lace's loop.

Repeat steps B through F down the lace line of the tent until the third grommet from the edge of the tent is reached, the third lace should be twice as long as all of the other loops (referred to as double loop). When the tent is laced down to

the third grommet (the double loop), pull the remaining 2 laces through the remaining 2 grommets. Loop the second lace from the tent perimeter into the first lace (the lace is now going towards the direction of the double loop). Pull the third lace (double loop) through the second loop. The third lace (double loop) should now be strung through 2 loops (the second loop and the fourth loop). Tie-off the double loop with the fourth lace so the loops can not come loose. Note: This does not in anyway affect the strength of the tent; it holds the tent sections together. A simple double knot is effective. After lacing each section, you will need to fasten down the rain flap that covers the lace line by clipping the spring clips onto the rain flap closer rope.

9. Place the tent top over the frame, by spreading the tent out on the 30' side and flapping the tent top while pulling it over the top. This, flapping, will make it easier to go over the frame and prevents any snags.

10. Secure the tent top to the frame by fastening the straps on the inside of the tent at each corner location.

11. Start at one corner and manually lift the frame so that the leg (7'8" black) can slide over the corner fitting. Pin the leg to the fitting. (When raising the tent, raise INTO the wind)

12. Proceed to work your way around the tent putting one leg in at a time until all legs are standing and pinned.

13. Now that the frame tent is erected, fasten the rest of tent top completely to the frame, using the straps on the inside of the tent. Make sure that all of the straps are tight and that the tent top is sitting evenly over the frame.

14. Drive a stake about four feet out from each leg and tie off the rope or ratchet to each leg.

Your tent installation is now complete.

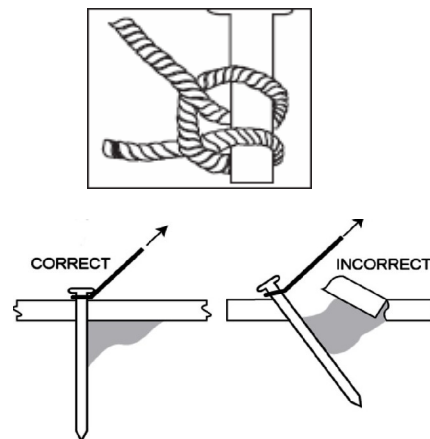

All Seasons Tent Sales

20 x 40 Frame Tent Set Up Instructions

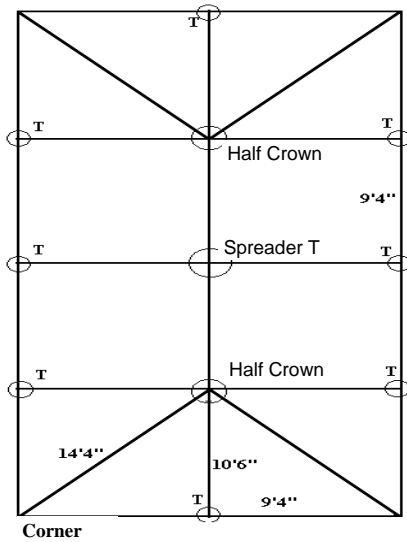

Pipe			
QTY	SIZE	COLOR	Style
4	14' 4"	Red	Hip Rafter
8	10' 6"	Green	Rafter
14	9'4"	White	Spreader
12	7' 8"	Black	Legs

Components	
QTY	Style
2	Half Crown
4	Regular Corners
8	Regular T's
1	Spreader T
12	Weights / Stakes
12	Ropes
64	Tent Pins
Optional Items	
1	Spreader Cable
1	Brace Package
12	Ratchets
12	Baseplates

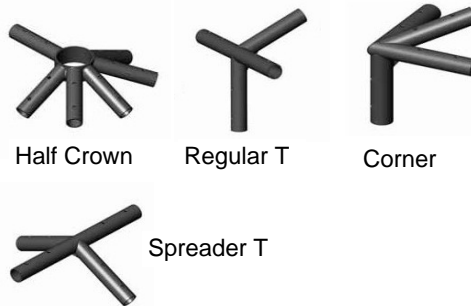

Pre-Site Inspection- Call your local utility companies prior to installation for any underground obstructions.

1. Layout the frame parts in the estimated location pertaining to the diagram. The spreader pipe is placed out to form the perimeter, and the rafters are laid in the interior location.
2. Start with one of the Half Crowns. Attach the hip rafters (14'4" red) to the Half Crown at the second and fourth points by sliding the pole over the fitting and lining up the holes in the pole with those in the fitting. Place a pin in the first hole to secure the pole in place.
3. Attach the Rafter poles (10'6" green) to the remaining points - one, three, and five of the Half Crown using the same technique as in step 2.
4. Attach a spreader (9'4" white) to the Half Crown, and connect it to the Spreader T. Connect another spreader (9'4" white) to the second Half Crown from the Spreader T. Repeat steps 2 & 3.
5. Attach the two remaining poles (10'6" green) to the Spreader T.
6. Connect the corner fittings to the hip rafter by sliding the pole over the fitting. Line up the hole of the pole with the first hole of the fitting and place a pin.
7. Join the regular t fittings to the poles by sliding the pole over the fitting. Line up the hole of the pole with the first hole of the fittings and place a pin.
8. The perimeter is ready for assembly. Connect the Regular T to the corners using the spreaders (9'4" white). Slide the poles over the fittings, line up the holes, and pin the pole and fitting together. When all of the spreaders have been secured in place, the frame will be complete.

OMIT next step if 1 Piece Top

Lace the tent together: A) Line up the two crown patches in the middle of the tent section (the lace end will always be on the bottom). Starting in the middle and working out, B) Pull the first lace up through the first small grommet. C) Pull the second lace through the second grommet. D) Pull the second lace through the first lace's loop. E) Pull the third lace through third grommet. F) Pull the third lace through the second lace's loop.

Repeat steps B through F down the lace line of the tent until the third grommet from the edge of the tent is reached, the third lace should be twice as long as all of the other loops (referred to as double loop). When the tent is laced down to the third grommet (the double loop), pull the remaining 2 laces through the remaining 2 grommets. Loop the second lace from the tent perimeter into the first lace (the lace is now going towards the direction of the double loop). Pull the third lace (double loop) through the second loop. The third lace (double loop) should now be strung through 2 loops (the second loop and the fourth loop). Tie-off the double loop with the fourth lace so the loops can not come loose. Note: This does not in anyway affect the strength of the tent; it holds the tent sections together. A simple double knot is effective. After lacing each section, you will need to fasten down the rain flap that covers the lace line by clipping the spring clips onto the rain flap closer rope.

9. Place the tent top over the frame, by spreading the tent out on the 40' side and flapping the tent top while pulling it over the top. This, flapping, will make it easier to go over the frame and prevents any snags.

10. Secure the tent top to the frame by fastening the straps on the inside of the tent at each corner location.

11. Start at one corner and manually lift the frame so that the leg (7'8" black) can slide over the corner fitting. Pin the leg to the fitting. (When raising the tent, raise INTO the wind)

12. Proceed to work your way around the tent putting one leg in at a time until all legs are standing and pinned.

13. Now that the frame tent is erected, fasten the rest of tent top completely to the frame, using the straps on the inside of the tent. Make sure that all of the straps are tight and that the tent top is sitting evenly over the frame.

14. Drive a stake about four feet out from each leg and tie off the rope or ratchet to each leg.

Your tent installation is now complete.

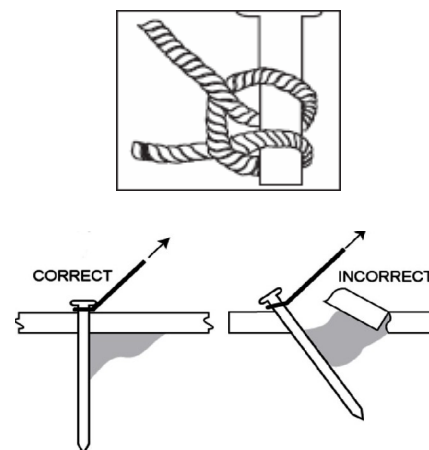

All Seasons Tent Sales

20 x 50 Frame Tent Set Up Instructions

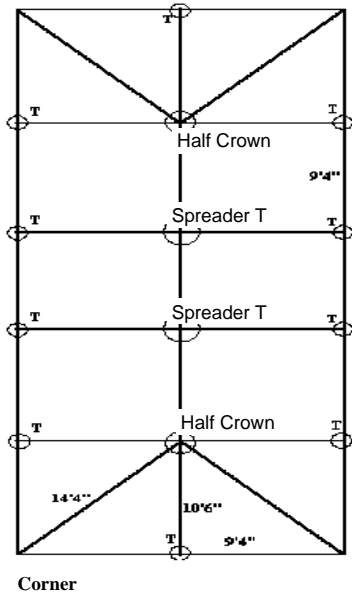

Pipe			
QTY	SIZE	COLOR	Style
4	14' 4"	Red	Hip Rafter
10	10' 6"	Green	Rafter
17	9'4"	White	Spreader
14	7' 8"	Black	Legs

Components	
QTY	Style
2	Half Crown
4	Regular Corners
10	Regular T's
2	Spreader T
14	Weights / Stakes
14	Ropes
76	Tent Pins
Optional Items	
2	Spreader Cable
1	Brace Package
14	Ratchets
14	Baseplates

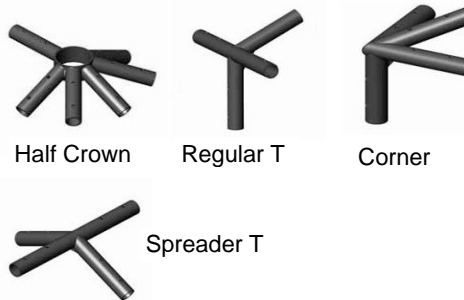

Pre-Site Inspection- Call your local utility companies prior to installation for any underground obstructions.

1. Layout the frame parts in the estimated location pertaining to the diagram. The spreader pipe is placed out to form the perimeter, and the rafters are laid in the interior location.
2. Start with one of the Half Crowns. Attach the hip rafters (14'4" red) to the Half Crown at the second and fourth points by sliding the pole over the fitting and lining up the holes in the pole with those in the fitting. Place a pin in the first hole to secure the pole in place.
3. Attach the Rafter poles (10'6" green) to the remaining points - one, three, and five of the Half Crown using the same technique as in step 2.
4. Attach a spreader (9'4" white) to the Half Crown, and connect it to the Spreader T. Connect another spreader (9'4" white) to the second Half Crown from the Spreader T. Repeat steps 2 & 3.
5. Attach the two remaining poles (10'6" green) to the Spreader T.
6. Connect the corner fittings to the hip rafter by sliding the pole over the fitting. Line up the hole of the pole with the first hole of the fitting and place a pin.
7. Join the regular t fittings to the poles by sliding the pole over the fitting. Line up the hole of the pole with the first hole of the fittings and place a pin.
8. The perimeter is ready for assembly. Connect the Regular T to the corners using the spreaders (9'4" white). Slide the poles over the fittings, line up the holes, and pin the pole and fitting together. When all of the spreaders have been secured in place, the frame will be complete.

OMIT next step if 1 Piece Top

Lace the tent together: A) Line up the two crown patches in the middle of the tent section (the lace end will always be on the bottom). Starting in the middle and working out, B) Pull the first lace up through the first small grommet. C) Pull the second lace through the second grommet. D) Pull the second lace through the first lace's loop. E) Pull the third lace through third grommet. F) Pull the third lace through the second lace's loop.

Repeat steps B through F down the lace line of the tent until the third grommet from the edge of the tent is reached, the third lace should be twice as long as all of the other loops (referred to as double loop). When the tent is laced down to the third grommet (the double loop), pull the remaining 2 laces through the remaining 2 grommets. Loop the second lace from the tent perimeter into the first lace (the lace is now going towards the direction of the double loop). Pull the third lace (double loop) through the second loop. The third lace (double loop) should now be strung through 2 loops (the second loop and the fourth loop). Tie-off the double loop with the fourth lace so the loops can not come loose. Note: This does not in anyway affect the strength of the tent; it holds the tent sections together. A simple double knot is effective. After lacing each section, you will need to fasten down the rain flap that covers the lace line by clipping the spring clips onto the rain flap closer rope.

9. Place the tent top over the frame, by spreading the tent out on the 50' side and flapping the tent top while pulling it over the top. This, flapping, will make it easier to go over the frame and prevents any snags.

10. Secure the tent top to the frame by fastening the straps on the inside of the tent at each corner location.

11. Start at one corner and manually lift the frame so that the leg (7'8" black) can slide over the corner fitting. Pin the leg to the fitting. (When raising the tent, raise INTO the wind)

12. Proceed to work your way around the tent putting one leg in at a time until all legs are standing and pinned.

13. Now that the frame tent is erected, fasten the rest of tent top completely to the frame, using the straps on the inside of the tent. Make sure that all of the straps are tight and that the tent top is sitting evenly over the frame.

14. Drive a stake about four feet out from each leg and tie off the rope or ratchet to each leg.

Your tent installation is now complete.

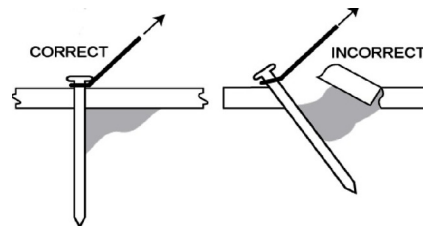
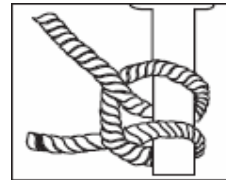

All Seasons Tent Sales

20 x 60 Frame Tent Set Up Instructions

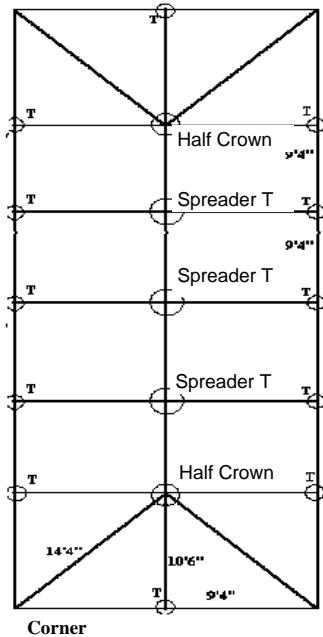

Pipe			
QTY	SIZE	COLOR	Style
4	14' 4"	Red	Hip Rafter
12	10' 6"	Green	Rafter
20	9' 4"	White	Spreader
16	7' 8"	Black	Legs

Components	
QTY	Style
2	Half Crown
4	Regular Corners
12	Regular T's
3	Spreader T
16	Weights / Stakes
16	Ropes
88	Tent Pins
Optional Items	
3	Spreader Cable
1	Brace Package
16	Ratchets
16	Baseplates

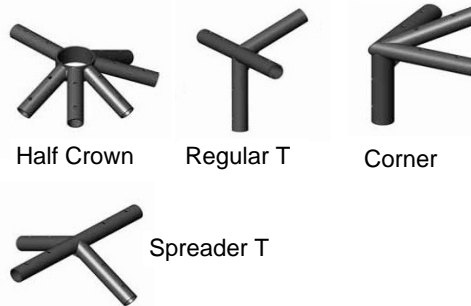

Pre-Site Inspection- Call your local utility companies prior to installation for any underground obstructions.

1. Layout the frame parts in the estimated location pertaining to the diagram. The spreader pipe is placed out to form the perimeter, and the rafters are laid in the interior location.
2. Start with one of the Half Crowns. Attach the hip rafters (14'4" red) to the Half Crown at the second and fourth points by sliding the pole over the fitting and lining up the holes in the pole with those in the fitting. Place a pin in the first hole to secure the pole in place.
3. Attach the Rafter poles (10'6" green) to the remaining points - one, three, and five of the Half Crown using the same technique as in step 2.
4. Attach a spreader (9'4" white) to the Half Crown, and connect it to the Spreader T. Connect another spreader (9'4" white) to the second Half Crown from the Spreader T. Repeat steps 2 & 3.
5. Attach the two remaining poles (10'6" green) to the Spreader T.
6. Connect the corner fittings to the hip rafter by sliding the pole over the fitting. Line up the hole of the pole with the first hole of the fitting and place a pin.
7. Join the regular t fittings to the poles by sliding the pole over the fitting. Line up the hole of the pole with the first hole of the fittings and place a pin.
8. The perimeter is ready for assembly. Connect the Regular T to the corners using the spreaders (9'4" white). Slide the poles over the fittings, line up the holes, and pin the pole and fitting together. When all of the spreaders have been secured in place, the frame will be complete.

OMIT next step if 1 Piece Top

Lace the tent together: A) Line up the two crown patches in the middle of the tent section (the lace end will always be on the bottom). Starting in the middle and working out, B) Pull the first lace up through the first small grommet. C) Pull the second lace through the second grommet. D) Pull the second lace through the first lace's loop. E) Pull the third lace through third grommet. F) Pull the third lace through the second lace's loop.

Repeat steps B through F down the lace line of the tent until the third grommet from the edge of the tent is reached, the third lace should be twice as long as all of the other loops (referred to as double loop). When the tent is laced down to the third grommet (the double loop), pull the remaining 2 laces through the remaining 2 grommets. Loop the second lace from the tent perimeter into the first lace (the lace is now going towards the direction of the double loop). Pull the third lace (double loop) through the second loop. The third lace (double loop) should now be strung through 2 loops (the second loop and the fourth loop). Tie-off the double loop with the fourth lace so the loops can not come loose. Note: This does not in anyway affect the strength of the tent; it holds the tent sections together. A simple double knot is effective. After lacing each section, you will need to fasten down the rain flap that covers the lace line by clipping the spring clips onto the rain flap closer rope.

9. Place the tent top over the frame, by spreading the tent out on the 60' side and flapping the tent top while pulling it over the top. This, flapping, will make it easier to go over the frame and prevents any snags.

10. Secure the tent top to the frame by fastening the straps on the inside of the tent at each corner location.

11. Start at one corner and manually lift the frame so that the leg (7'8" black) can slide over the corner fitting. Pin the leg to the fitting. (When raising the tent, raise INTO the wind)

12. Proceed to work your way around the tent putting one leg in at a time until all legs are standing and pinned.

13. Now that the frame tent is erected, fasten the rest of tent top completely to the frame, using the straps on the inside of the tent. Make sure that all of the straps are tight and that the tent top is sitting evenly over the frame.

14. Drive a stake about four feet out from each leg and tie off the rope or ratchet to each leg.

Your tent installation is now complete.

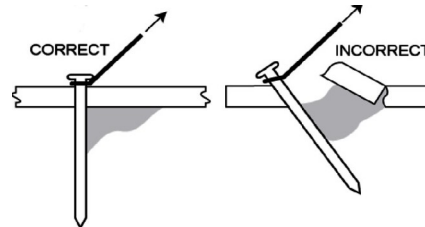
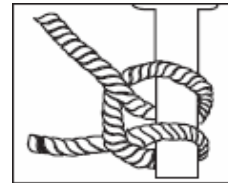

All Seasons Tent Sales

30 x 30 Frame Tent Set Up Instructions

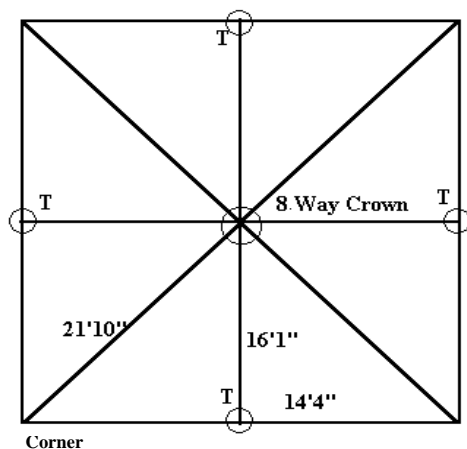

Pipe			
QTY	SIZE	COLOR	Style
4	21'10"	Orange	Hip Rafter
4	16'1"	Brown	Rafter
8	14'4"	Red	Spreader
8	7' 8"	Black	Legs



8 Way Crown



Regular T



Corner

Components	
QTY	Style
1	8 Way Crown
4	Regular Corners
4	Regular T's
8	Weights / Stakes
8	Ropes
40	Tent Pins
Optional Items	
1	Brace Package
8	Ratchets
8	Baseplates

Pre-Site Inspection- Call your local utility companies prior to installation for any underground obstructions.

1. Layout the frame parts in the estimated location pertaining to the diagram. The spreader pipe is placed out to form the perimeter, and the rafters are laid in the interior location.
2. Start with the 8 way crown. Lay the crown on a flat surface to determine the correct placement, when the crown is on a flat surface the angles that are not touching the ground (every other one) will correlate with the 4 corners. Attach the hip rafters (21' 10" orange) to the 8 way crown at the angles, that do not touch the ground, by sliding the pole in or over the fitting and lining up the holes in the pole with those in the fitting. Place a pin in the first hole to secure the pole in place. Repeat at all four corners.
3. Attach the poles (16'1" brown) to the remaining angles of the 8 way crown using the same technique as in step 2.
4. Connect the corner fitting to the hip rafter by sliding the pole in or over the fitting. Line up the hole of the pole with those of the fitting and place a pin.
5. Join the Regular T fitting to the rafters by sliding the pole over the fitting. Line up the hole of the pole with those of the fitting and place a pin.
6. The perimeter is ready for assembly. Connect the Regular T to the corners using the spreaders (14'4" red). Slide the poles over the fittings, line up the holes, and pin the pole and fitting together. When all of the spreaders have been secured in place, the frame will be complete.

OMIT next step if 1 Piece Top

Lace the tent together: A) Line up the two crown patches in the middle of the tent section (the lace end will always be on the bottom). Starting in the middle and working out, B) Pull the first lace up through the first small grommet. C) Pull the second lace through the second grommet. D) Pull the second lace through the first lace's loop. E) Pull the third lace through third grommet. F) Pull the third lace through the second lace's loop. Repeat steps B through F down the lace line of the tent until the third grommet from the edge of the tent is reached, the third lace should be twice as long as all of the other loops (referred to as double loop). When the tent is laced down to the third grommet (the double loop), pull the remaining 2 laces through the remaining 2 grommets. Loop the second lace from the tent perimeter into the first lace (the lace is now going towards the direction of the double loop). Pull the third lace (double loop) through the second loop. The third lace (double loop) should now be strung through 2 loops (the second loop and the fourth loop). Tie-off the double loop with the fourth lace so the loops can not come loose. Note: This

does not in anyway affect the strength of the tent; it holds the tent sections together. A simple double knot is effective. After lacing each section, you will need to fasten down the rain flap that covers the lace line by clipping the spring clips onto the rain flap closer rope.

7. Place the tent top over the frame, by spreading the tent out on one end and flapping the tent top while pulling it over the top. This, flapping, will make it easier to go over the frame and prevents any snags.

8. Secure the tent top to the frame by fastening the straps on the inside of the tent at each corner location.

9. Start at one corner and manually lift the frame so that the leg (7'8" black) can slide over the corner fitting. Pin the leg to the fitting. (When raising the tent, raise INTO the wind)

10. Proceed to work your way around the tent putting one leg in at a time until all legs are standing and pinned.

11. Now that the frame tent is erected, fasten the rest of tent top completely to the frame, using the straps on the inside of the tent. Make sure that all of the straps are tight and that the tent top is sitting evenly over the frame.

12. Drive a stake about four feet out from each leg and tie off the rope or ratchet to each leg.

Your tent installation is now complete.

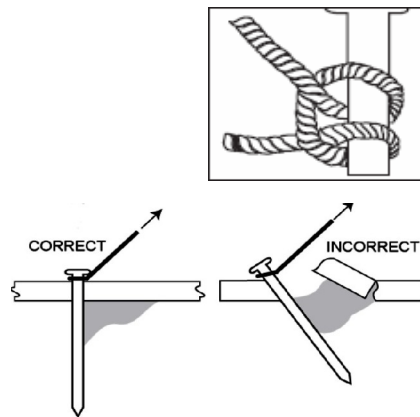

All Seasons Tent Sales

30 x 40 Frame Tent Set Up Instructions

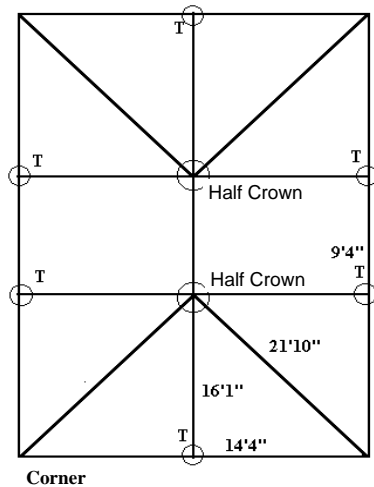

Pipe			
QTY	SIZE	COLOR	Style
4	21'10"	Orange	Hip Rafter
6	16'1"	Brown	Rafter
8	14'4"	Red	Spreader
3	9'4"	White	Spreader
10	7' 8"	Black	Legs

Components	
QTY	Style
2	Half Crown
4	Regular Corners
6	Regular T's
10	Weights / Stakes
10	Ropes
52	Tent Pins
Optional Items	
1	Brace Package
1	Spreader Cable
10	Ratchets
10	Baseplates

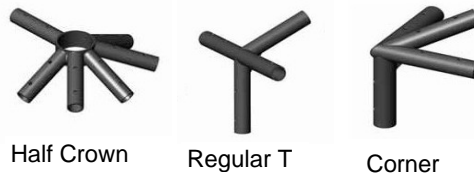

Pre-Site Inspection- Call your local utility companies prior to installation for any underground obstructions.

1. Layout the frame parts in the estimated location pertaining to the diagram. The spreader pipe is placed out to form the perimeter, and the rafters are laid in the interior location.
2. Start with one of the Half Crowns. Attach the hip rafters (21' 10" orange) to the Half Crown at the second and fourth points by sliding the pole over the fitting and lining up the holes in the pole with those in the fitting. Place a pin in the first hole to secure the pole in place.
3. Attach the poles (16'1" brown) to the remaining points - one, three, and five of the Half Crown using the same technique as in step 2.
4. Attach a spreader (9'4" white) to the Half Crown, and connect it to the other Half Crown.
5. Connect the corner fittings to the hip rafter by sliding the pole over the fitting. Line up the hole of the pole with the first hole of the fitting and place a pin.
6. Join the regular t fittings to the poles by sliding the pole over the fitting. Line up the hole of the pole with the first hole of the fittings and place a pin.
7. The perimeter is ready for assembly. Connect the Regular T's to the corners using the spreaders (14'4" red) and connect the regular t's to the regular t's using the spreaders (9'4" white). Slide the poles over the fittings, line up the holes, and pin the pole and fitting together. When all of the spreaders have been secured in place, the frame will be complete.

OMIT next step if 1 Piece Top

Lace the tent together: A) Line up the two crown patches in the middle of the tent section (the lace end will always be on the bottom). Starting in the middle and working out, B) Pull the first lace up through the first small grommet. C) Pull the second lace through the second grommet. D) Pull the second lace through the first lace's loop. E) Pull the third

lace through third grommet. F) Pull the third lace through the second lace's loop.

Repeat steps B through F down the lace line of the tent until the third grommet from the edge of the tent is reached, the third lace should be twice as long as all of the other loops (referred to as double loop). When the tent is laced down to the third grommet (the double loop), pull the remaining 2 laces through the remaining 2 grommets. Loop the second lace from the tent perimeter into the first lace (the lace is now going towards the direction of the double loop). Pull the third lace (double loop) through the second loop. The third lace (double loop) should now be strung through 2 loops (the second loop and the fourth loop). Tie-off the double loop with the fourth lace so the loops can not come loose. Note: This does not in anyway affect the strength of the tent; it holds the tent sections together. A simple double knot is effective. After lacing each section, you will need to fasten down the rain flap that covers the lace line by clipping the spring clips onto the rain flap closer rope.

8. Place the tent top over the frame, by spreading the tent out on the 40' side and flapping the tent top while pulling it over the top. This, flapping, will make it easier to go over the frame and prevents any snags.

9. Secure the tent top to the frame by fastening the straps on the inside of the tent at each corner location.

10. Start at one corner and manually lift the frame so that the leg (7'8" black) can slide over the corner fitting. Pin the leg to the fitting. (When raising the tent, raise INTO the wind)

11. Proceed to work your way around the tent putting one leg in at a time until all legs are standing and pinned.

12. Now that the frame tent is erected, fasten the rest of tent top completely to the frame, using the straps on the inside of the tent. Make sure that all of the straps are tight and that the tent top is sitting evenly over the frame.

13. Drive a stake about four feet out from each leg and tie off the rope or ratchet to each leg.

Your tent installation is now complete.

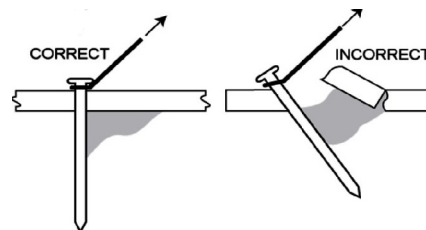
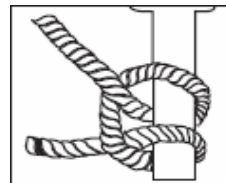

All Seasons Tent Sales

30 x 50 Frame Tent Set Up Instructions

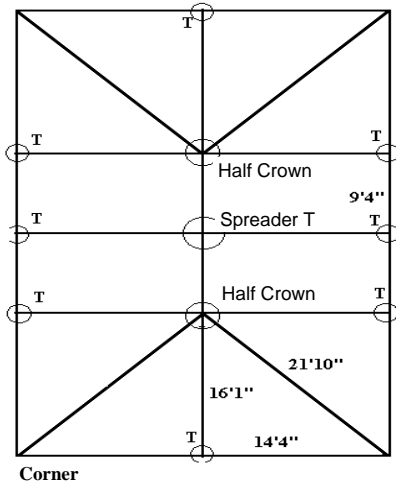

Pipe			
QTY	SIZE	COLOR	Style
4	21'10"	Orange	Hip Rafter
8	16'1"	Brown	Rafter
8	14'4"	Red	Spreader
6	9'4"	White	Spreader
12	7'8"	Black	Legs

Components	
QTY	Style
2	Half Crown
4	Regular Corners
8	Regular T's
1	Spreader T
12	Weights / Stakes
12	Ropes
64	Tent Pins
Optional Items	
1	Brace Package
2	Spreader Cables
12	Ratchets
12	Baseplates

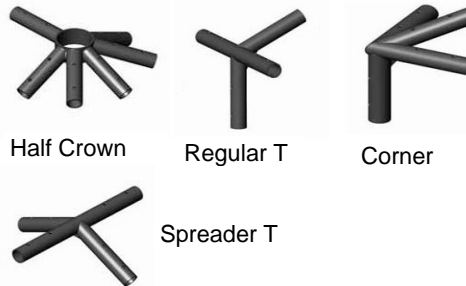

Pre-Site Inspection- Call your local utility companies prior to installation for any underground obstructions.

1. Layout the frame parts in the estimated location pertaining to the diagram. The spreader pipe is placed out to form the perimeter, and the rafters are laid in the interior location.

2. Start with one of the Half Crowns. Attach the hip rafters (21' 10" orange) to the Half Crown at the second and fourth points by sliding the pole over the fitting and lining up the holes in the pole with those in the fitting. Place a pin in the first hole to secure the pole in place.

3. Attach the Rafter poles (16' 1" brown) to the remaining points - one, three, and five of the Half Crown using the same technique as in step 2.

4. Attach a spreader (9'4" white) to the Half Crown, and connect it to the Spreader T. Connect another spreader (9'4" white) to the second Half Crown from the Spreader T. Repeat steps 2 & 3.

5. Attach the two remaining poles (16' 1" brown) to the Spreader T.

6. Connect the corner fittings to the hip rafter by sliding the pole over the fitting. Line up the hole of the pole with the first hole of the fitting and place a pin.

7. Join the regular t fittings to the poles by sliding the pole over the fitting. Line up the hole of the pole with the first hole of the fittings and place a pin.

8. The perimeter is ready for assembly. Connect the Regular T's to the corners using the spreaders (14'4" red) and connect the regular t's to the regular t's using the spreaders (9'4" white). Slide the poles over the fittings, line up the holes, and pin the pole and fitting together. When all of the spreaders have been secured in place, the frame will be complete.

OMIT next step if 1 Piece Top

Lace the tent together: A) Line up the two crown patches in the middle of the tent section (the lace end will always be on the bottom). Starting in the middle and working out, B) Pull the first lace up through the first small grommet. C) Pull the second lace through the second grommet. D) Pull the second lace through the first lace's loop. E) Pull the third lace through third grommet. F) Pull the third lace through the second lace's loop.

Repeat steps B through F down the lace line of the tent until the third grommet from the edge of the tent is reached, the third lace should be twice as long as all of the other loops (referred to as double loop). When the tent is laced down to the third grommet (the double loop), pull the remaining 2 laces through the remaining 2 grommets. Loop the second lace from the tent perimeter into the first lace (the lace is now going towards the direction of the double loop). Pull the third lace (double loop) through the second loop. The third lace (double loop) should now be strung through 2 loops (the second loop and the fourth loop). Tie-off the double loop with the fourth lace so the loops can not come loose. Note: This does not in anyway affect the strength of the tent; it holds the tent sections together. A simple double knot is effective. After lacing each section, you will need to fasten down the rain flap that covers the lace line by clipping the spring clips onto the rain flap closer rope.

9. Place the tent top over the frame, by spreading the tent out on the 50' side and flapping the tent top while pulling it over the top. This, flapping, will make it easier to go over the frame and prevents any snags.

10. Secure the tent top to the frame by fastening the straps on the inside of the tent at each corner location.

11. Start at one corner and manually lift the frame so that the leg (7'8" black) can slide over the corner fitting. Pin the leg to the fitting. (When raising the tent, raise INTO the wind)

12. Proceed to work your way around the tent putting one leg in at a time until all legs are standing and pinned.

13. Now that the frame tent is erected, fasten the rest of tent top completely to the frame, using the straps on the inside of the tent. Make sure that all of the straps are tight and that the tent top is sitting evenly over the frame.

14. Drive a stake about four feet out from each leg and tie off the rope or ratchet to each leg.

Your tent installation is now complete.

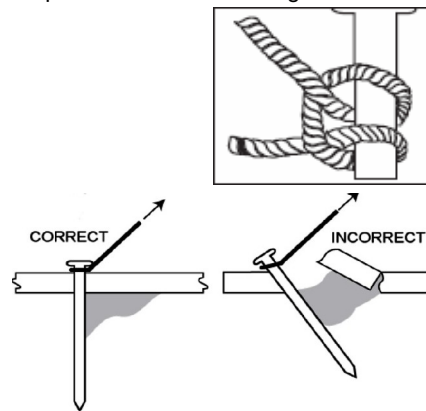

All Seasons Tent Sales

30 x 60 Frame Tent Set Up Instructions

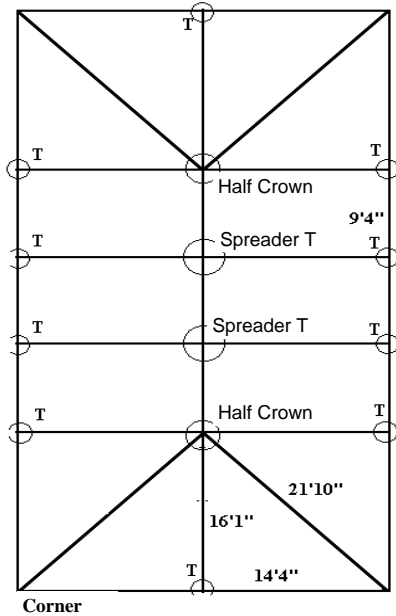

Pipe			
QTY	SIZE	COLOR	Style
4	21'10"	Orange	Hip Rafter
10	16'1"	Brown	Rafter
8	14'4"	Red	Spreader
9	9'4"	White	Spreader
14	7' 8"	Black	Legs

Components	
QTY	Style
2	Half Crown
4	Regular Corners
10	Regular T's
2	Spreader T
14	Weights / Stakes
14	Ropes
76	Tent Pins
Optional Items	
1	Brace Package
3	Spreader Cables
14	Ratchets
14	Baseplates

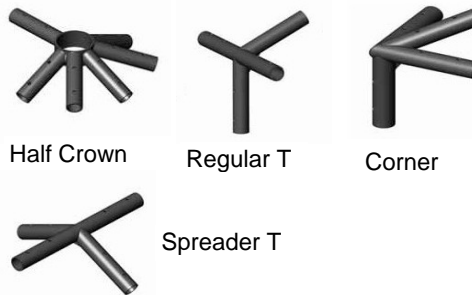

Pre-Site Inspection- Call your local utility companies prior to installation for any underground obstructions.

1. Layout the frame parts in the estimated location pertaining to the diagram. The spreader pipe is placed out to form the perimeter, and the rafters are laid in the interior location.
2. Start with one of the Half Crowns. Attach the hip rafters (21' 10" orange) to the Half Crown at the second and fourth points by sliding the pole over the fitting and lining up the holes in the pole with those in the fitting. Place a pin in the first hole to secure the pole in place.
3. Attach the Rafter poles (16' 1" brown) to the remaining points - one, three, and five of the Half Crown using the same technique as in step 2.
4. Attach a spreader (9'4" white) to the Half Crown, and connect it to the Spreader T. Connect another spreader (9'4" white) to the second Half Crown from the Spreader T. Repeat steps 2 & 3.
5. Attach the two remaining poles (16' 1" brown) to the Spreader T.
6. Connect the corner fittings to the hip rafter by sliding the pole over the fitting. Line up the hole of the pole with the first hole of the fitting and place a pin.
7. Join the regular t fittings to the poles by sliding the pole over the fitting. Line up the hole of the pole with the first hole of the fittings and place a pin.
8. The perimeter is ready for assembly. Connect the Regular T's to the corners using the spreaders (14'4" red) and connect the regular t's to the regular t's using the spreaders (9'4" white). Slide the poles over the fittings, line up the holes, and pin the pole and fitting together. When all of the spreaders have been secured in place, the frame will be complete.

NOTE - The tent top now needs to be laced together. It is best to do this on the ground along the length of the frame if space permits. The tent can be laced together while over the frame, but is more difficult and time consuming.

OMIT next step if 1 Piece Top

Lace the tent together: A) Line up the two crown patches in the middle of the tent section (the lace end will always be on the bottom). Starting in the middle and working out, B) Pull the first lace up through the first small grommet. C) Pull the second lace through the second grommet. D) Pull the second lace through the first lace's loop. E) Pull the third lace through third grommet. F) Pull the third lace through the second lace's loop.

Repeat steps B through F down the lace line of the tent until the third grommet from the edge of the tent is reached, the third lace should be twice as long as all of the other loops (referred to as double loop). When the tent is laced down to the third grommet (the double loop), pull the remaining 2 laces through the remaining 2 grommets. Loop the second lace from the tent perimeter into the first lace (the lace is now going towards the direction of the double loop). Pull the third lace (double loop) through the second loop. The third lace (double loop) should now be strung through 2 loops (the second loop and the fourth loop). Tie-off the double loop with the fourth lace so the loops can not come loose. Note: This does not in anyway affect the strength of the tent; it holds the tent sections together. A simple double knot is effective. After lacing each section, you will need to fasten down the rain flap that covers the lace line by clipping the spring clips onto the rain flap closer rope.

9. Place the tent top over the frame, by spreading the tent out on the 60' side and flapping the tent top while pulling it over the top. This, flapping, will make it easier to go over the frame and prevents any snags.

10. Secure the tent top to the frame by fastening the straps on the inside of the tent at each corner location.

11. Start at one corner and manually lift the frame so that the leg (7'8" black) can slide over the corner fitting. Pin the leg to the fitting. (When raising the tent, raise INTO the wind)

12. Proceed to work your way around the tent putting one leg in at a time until all legs are standing and pinned.

13. Now that the frame tent is erected, fasten the rest of tent top completely to the frame, using the straps on the inside of the tent. Make sure that all of the straps are tight and that the tent top is sitting evenly over the frame.

14. Drive a stake about four feet out from each leg and tie off the rope or ratchet to each leg.

Your tent installation is now complete.

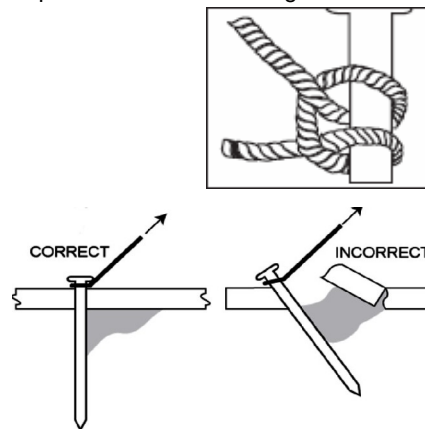

All Seasons Tent Sales

30 x 60 w/ 15 ft middle Frame Tent Set Up Instructions

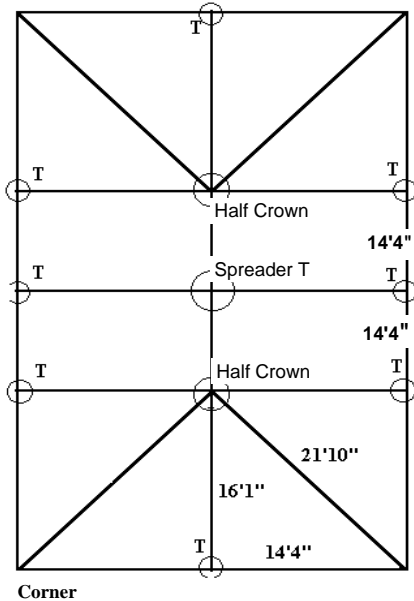

Pipe			
QTY	SIZE	COLOR	Style
4	21'10"	Orange	Hip Rafter
8	16'1"	Brown	Rafter
14	14'4"	Red	Spreader
12	7' 8"	Black	Legs

Components	
QTY	Style
2	Half Crown
4	Regular Corners
8	Regular T's
1	Spreader T
12	Weights / Stakes
12	Ropes
64	Tent Pins
Optional Items	
1	Brace Package
3	Spreader Cables
12	Ratchets
12	Baseplates

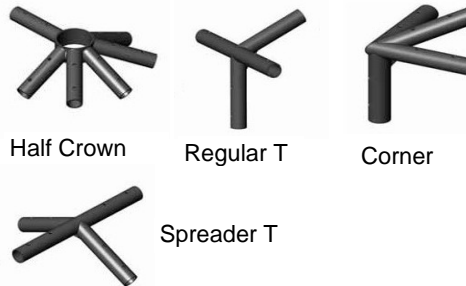

Pre-Site Inspection- Call your local utility companies prior to installation for any underground obstructions.

1. Layout the frame parts in the estimated location pertaining to the diagram. The spreader pipe is placed out to form the perimeter, and the rafters are laid in the interior location.
2. Start with one of the Half Crowns. Attach the hip rafters (21' 10" orange) to the Half Crown at the second and fourth points by sliding the pole over the fitting and lining up the holes in the pole with those in the fitting. Place a pin in the first hole to secure the pole in place.
3. Attach the Rafter poles (16' 1" brown) to the remaining points - one, three, and five of the Half Crown using the same technique as in step 2.
4. Attach a spreader (9'4" white) to the Half Crown, and connect it to the Spreader T. Connect another spreader (9'4" white) to the second Half Crown from the Spreader T. Repeat steps 2 & 3.
5. Attach the two remaining poles (16' 1" brown) to the Spreader T.
6. Connect the corner fittings to the hip rafter by sliding the pole over the fitting. Line up the hole of the pole with the first hole of the fitting and place a pin.
7. Join the regular t fittings to the poles by sliding the pole over the fitting. Line up the hole of the pole with the first hole of the fittings and place a pin.
8. The perimeter is ready for assembly. Connect the Regular T's to the corners using the spreaders (14'4" red) and connect the regular t's to the regular t's using the spreaders (14'4" red). Slide the poles over the fittings, line up the holes, and pin the pole and fitting together. When all of the spreaders have been secured in place, the frame will be complete.

NOTE - The tent top now needs to be laced together. It is best to do this on the ground along the length of the frame if space permits. The tent can be laced together while over the frame, but is more difficult and time consuming.

OMIT next step if 1 Piece Top

Lace the tent together: A) Line up the two crown patches in the middle of the tent section (the lace end will always be on the bottom). Starting in the middle and working out, B) Pull the first lace up through the first small grommet. C) Pull the second lace through the second grommet. D) Pull the second lace through the first lace's loop. E) Pull the third lace through third grommet. F) Pull the third lace through the second lace's loop.

Repeat steps B through F down the lace line of the tent until the third grommet from the edge of the tent is reached, the third lace should be twice as long as all of the other loops (referred to as double loop). When the tent is laced down to the third grommet (the double loop), pull the remaining 2 laces through the remaining 2 grommets. Loop the second lace from the tent perimeter into the first lace (the lace is now going towards the direction of the double loop). Pull the third lace (double loop) through the second loop. The third lace (double loop) should now be strung through 2 loops (the second loop and the fourth loop). Tie-off the double loop with the fourth lace so the loops can not come loose. Note: This does not in anyway affect the strength of the tent; it holds the tent sections together. A simple double knot is effective. After lacing each section, you will need to fasten down the rain flap that covers the lace line by clipping the spring clips onto the rain flap closer rope.

9. Place the tent top over the frame, by spreading the tent out on the 60' side and flapping the tent top while pulling it over the top. This, flapping, will make it easier to go over the frame and prevents any snags.

10. Secure the tent top to the frame by fastening the straps on the inside of the tent at each corner location.

11. Start at one corner and manually lift the frame so that the leg (7'8" black) can slide over the corner fitting. Pin the leg to the fitting. (When raising the tent, raise INTO the wind)

12. Proceed to work your way around the tent putting one leg in at a time until all legs are standing and pinned.

13. Now that the frame tent is erected, fasten the rest of tent top completely to the frame, using the straps on the inside of the tent. Make sure that all of the straps are tight and that the tent top is sitting evenly over the frame.

14. Drive a stake about four feet out from each leg and tie off the rope or ratchet to each leg.

Your tent installation is now complete.

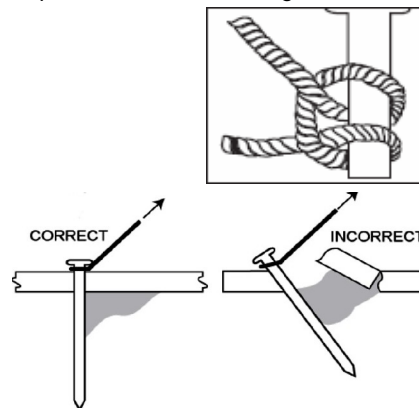

All Seasons Tent Sales

40 x 40 Frame Tent Set Up Instructions

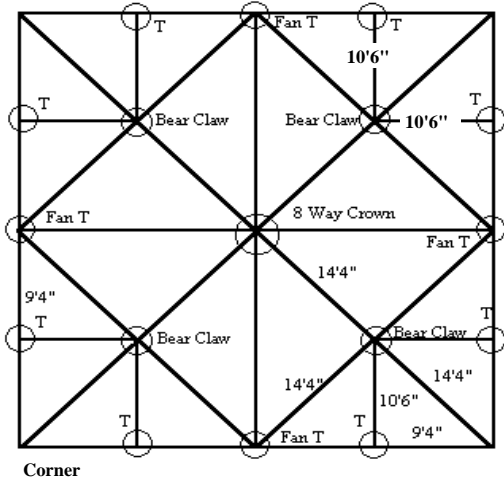

Pipe			
QTY	SIZE	COLOR	Style
4	21'10"	Orange	Rafter
16	14'4"	Red	Hip Rafter
8	10'6"	Green	Corner Rafter
16	9'4"	White	Spreader
16	7'8"	Black	Legs

Components	
QTY	Style
1	8 Way Crown
4	Regular Corners
8	Regular T's
4	Bear Claws
4	Fan T
16	Weights / Stakes
16	Ropes
104	Tent Pins
Optional Items	
1	Brace Package
16	Ratchets
16	Baseplates

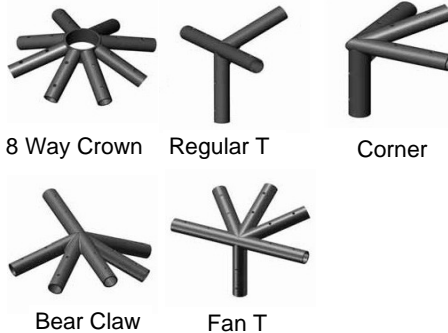

Pre-Site Inspection- Call your local utility companies prior to installation for any underground obstructions.

1. Layout the frame parts in the estimated location pertaining to the diagram. The spreader pipe is placed out to form the perimeter, and the rafters are laid in the interior location.
2. Start with the 8 way crown. Lay the crown on a flat surface to determine the correct placement, when the crown is on a flat surface the angles that are not touching the ground (every other one) will correlate with the 4 corners. Attach the hip rafters (14'4" red) to the 8 way crown at angle not touching the ground by sliding the pole over the fitting and lining up the holes in the pole with those in the fitting. Place a pin in the first hole to secure the pole in place. Repeat at all four corners.
3. Attach the poles (21'10" orange) to the remaining angles of the 8 way crown using the same technique as in step 2.
4. Attach the Bear Claw fittings to the 4 hip rafter (14'4" red), at point 6, by sliding the pole over the fitting. Line up the hole of the pole with those of the fitting and place a pin. Attach hip rafters (14'4" red) to the Bear Claw at points 1, 3, and 5. Attach corner rafters (10'6" green) to the Bear Claw fitting at points 2 and 4.
5. Attach the corner fitting to the hip rafter (point 3 only) by sliding the pole over the fitting. Line up the hole of the pole with those of the fitting and place a pin. Attach the Fan T to the rafters (21'10" orange) and to the hip rafters (points 1 & 5).
6. Join the regular t fittings to the corner poles (10'6" green) by sliding the pole over the fitting. Line up the hole of the pole with those of the fittings and place a pin.

7. The perimeter is ready for assembly. Connect the regular t's to the corners and fan t's using the spreaders (9'4" white). Slide the poles over the fittings, line up the holes, and pin the pole and fitting together. When all of the spreaders have been secured in place, the frame will be complete.

OMIT next step if 1 Piece Top

Lace the tent together: A) Line up the two crown patches in the middle of the tent section (the lace end will always be on the bottom). Starting in the middle and working out, B) Pull the first lace up through the first small grommet. C) Pull the second lace through the second grommet. D) Pull the second lace through the first lace's loop. E) Pull the third lace through third grommet. F) Pull the third lace through the second lace's loop. Repeat steps B through F down the lace line of the tent until the third grommet from the edge of the tent is reached, the third lace should be twice as long as all of the other loops (referred to as double loop). When the tent is laced down to the third grommet (the double loop), pull the remaining 2 laces through the remaining 2 grommets. Loop the second lace from the tent perimeter into the first lace (the lace is now going towards the direction of the double loop). Pull the third lace (double loop) through the second loop. The third lace (double loop) should now be strung through 2 loops (the second loop and the fourth loop). Tie-off the double loop with the fourth lace so the loops can not come loose. Note: This does not in anyway affect the strength of the tent; it holds the tent sections together. A simple double knot is effective. After lacing each section, you will need to fasten down the rain flap that covers the lace line by clipping the spring clips onto the rain flap closer rope.

8. Place the tent top over the frame, by spreading the tent out on one end and flapping the tent top while pulling it over the top. This, flapping, will make it easier to go over the frame and prevents any snags.

10. Secure the tent top to the frame by fastening the straps on the inside of the tent at each corner location.

11. Start at one corner and manually lift the frame so that the leg (7'8" black) can slide over the corner fitting. Pin the leg to the fitting. (When raising the tent, raise INTO the wind)

12. Proceed to work your way around the tent putting one leg in at a time until all legs are standing and pinned.

13. Now that the frame tent is erected, fasten the rest of tent top completely to the frame, using the straps on the inside of the tent. Make sure that all of the straps are tight and that the tent top is sitting evenly over the frame.

14. Drive a stake about four feet out from each leg and tie off the rope or ratchet to each leg.

Your tent installation is now complete.

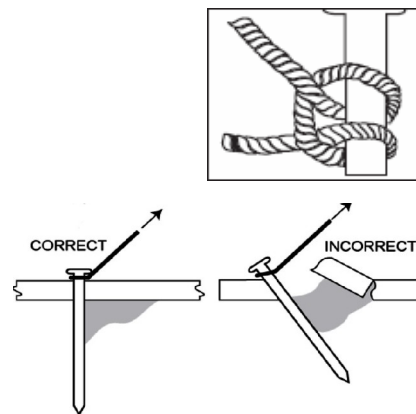

All Seasons Tent Sales

40 x 60 Frame Tent Set Up Instructions

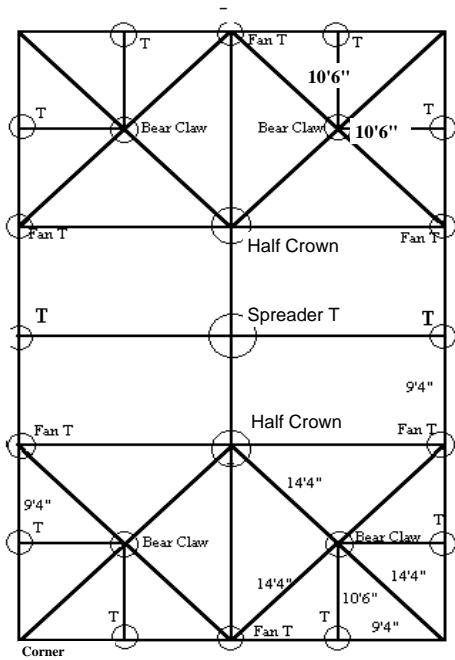

Pipe			
QTY	SIZE	COLOR	Style
8	21'10"	Orange	Rafter
16	14'4"	Red	Hip Rafter
8	10'6"	Green	Corner Rafter
22	9'4"	White	Spreader
20	7'8"	Black	Legs

Components	
QTY	Style
2	Half Crowns
4	Regular Corners
10	Regular T's
1	Spreader T
4	Bear Claws
6	Fan T
20	Weights / Stakes
20	Ropes
136	Tent Pins
Optional Items	
1	Brace Package
2	Spreader Cables
20	Ratchets
20	Baseplates

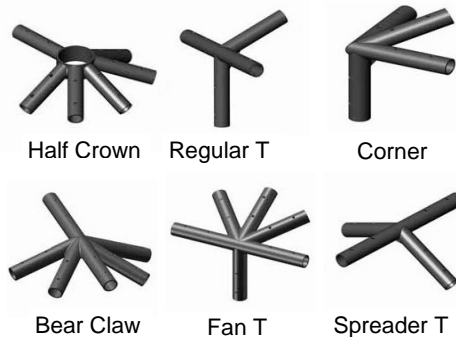

Pre-Site Inspection- Call your local utility companies prior to installation for any underground obstructions.

1. Layout the frame parts in the estimated location pertaining to the diagram. The spreader pipe is placed out to form the perimeter, and the rafters are laid in the interior location.
2. Start with one of the Half Crowns. Attach the poles (21'10" orange) to the Half Crown at points 1, 3, & 5 by sliding the pole over the fitting and lining up the holes in the pole with those in the fitting. Place a pin in the first hole to secure the pole in place.
3. Attach the hip rafter (14'4" red) to the remaining points of the Half Crown using the same technique as in step 2.
4. Attach a spreader (9'4" white) to the Half Crown, and connect it to the Spreader T. Attach another spreader (9'4" white) from the Spreader T to the Half Crown. Attach rafters (21'10" orange) to the Spreader T. Repeat steps 2 & 3.
5. Attach the Bear Claw fitting to the 4 hip poles (14'4" red) by sliding the pole over the fitting. Line up the hole of the pole with those of the fitting and place a pin. Attach hip rafters (14'4" red) to the Bear Claw fitting at points 1, 3, and 5.
6. Attach corner poles (10'6" green) to the Bear Claw fitting at points 2 and 4.
7. Attach the corner fitting to the hip rafter (point 3 only) by sliding the pole over the fitting. Line up the hole of the pole with those of the fitting and place a pin. Attach the Fan T's to the rafters (21'10" orange) and to the hip rafters (points 1 & 5).

8. Join the Regular T fittings to the corner poles (10'6" green) by sliding the pole over the fitting. Line up the hole of the pole with those of the fittings and place a pin.

9. The perimeter is ready for assembly. Connect the Regular T's to the corners and Fan T's using the spreaders (9'4" white). Slide the poles over the fittings, line up the holes, and pin the pole and fitting together. When all of the spreaders have been secured in place, the frame will be complete.

NOTE . The tent top now needs to be laced together. It is best to do this on the ground along the length of the frame if space permits. The tent can be laced together while over the frame, but is more difficult and time consuming.

10. Lace the tent together: A) Line up the two crown patches in the middle of the tent section (the lace end will always be on the bottom). Starting in the middle and working out, B) Pull the first lace up through the first small grommet. C) Pull the second lace through the second grommet. D) Pull the second lace through the first lace's loop. E) Pull the third lace through third grommet. F) Pull the third lace through the second lace's loop.

Repeat steps B through F down the lace line of the tent until the third grommet from the edge of the tent is reached, the third lace should be twice as long as all of the other loops (referred to as double loop). When the tent is laced down to the third grommet (the double loop), pull the remaining 2 laces through the remaining 2 grommets. Loop the second lace from the tent perimeter into the first lace (the lace is now going towards the direction of the double loop). Pull the third lace (double loop) through the second loop. The third lace (double loop) should now be strung through 2 loops (the second loop and the fourth loop). Tie-off the double loop with the fourth lace so the loops can not come loose. Note: This does not in anyway affect the strength of the tent; it holds the tent sections together. A simple double knot is effective. After lacing each section, you will need to fasten down the rain flap that covers the lace line by clipping the spring clips onto the rain flap closer rope.

11. Place the tent top over the frame, by spreading the tent out on the 60' end and flapping the tent top while pulling it over the top. This, flapping, will make it easier to go over the frame and prevents any snags.

12. Secure the tent top to the frame by fastening the straps on the inside of the tent at each corner location.

13. Start at one corner and manually lift the frame so that the leg (7'8" black) can slide over the corner fitting. Pin the leg to the fitting. (When raising the tent, raise INTO the wind)

14. Proceed to work your way around the tent putting one leg in at a time until all legs are standing and pinned.

15. Now that the frame tent is erected, fasten the rest of tent top completely to the frame, using the straps on the inside of the tent. Make sure that all of the straps are tight and that the tent top is sitting evenly over the frame.

16. Drive a stake about four feet out from each leg and tie off the rope or ratchet to each leg.

Your tent installation is now complete.

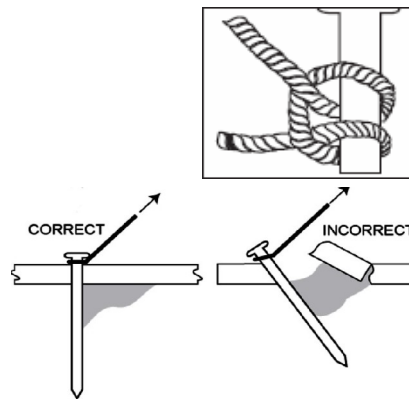

All Seasons Tent Sales

40 x 80 Frame Tent Set Up Instructions

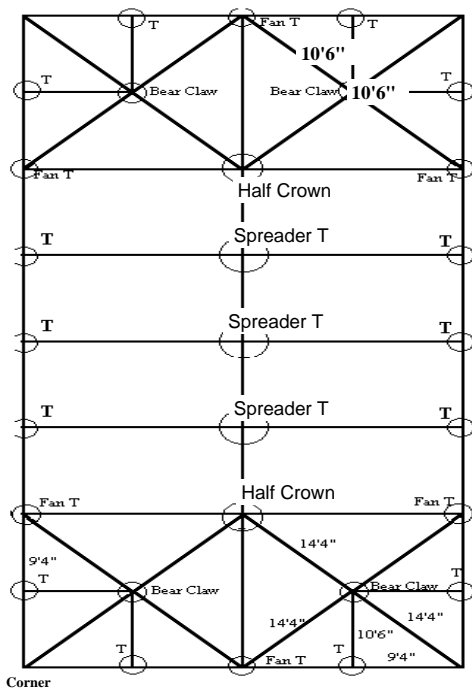

Pipe			
QTY	SIZE	COLOR	Style
12	21'10"	Orange	Rafter
16	14'4"	Red	Hip Rafter
8	10'6"	Green	Corner Rafter
28	9'4"	White	Spreader
24	7' 8"	Black	Legs

Components	
QTY	Style
2	Half Crowns
4	Regular Corners
14	Regular T's
3	Spreader T
4	Bear Claws
6	Fan T
24	Weights / Stakes
24	Ropes
164	Tent Pins
Optional Items	
1	Brace Package
3	Spreader Cables
24	Ratchets
24	Baseplates

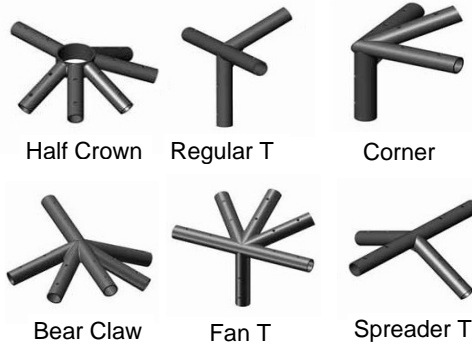

Pre-Site Inspection- Call your local utility companies prior to installation for any underground obstructions.

1. Layout the frame parts in the estimated location pertaining to the diagram. The spreader pipe is placed out to form the perimeter, and the rafters are laid in the interior location.
2. Start with one of the Half Crowns. Attach the poles (21'10" orange) to the Half Crown at points 1, 3, & 5 by sliding the pole over the fitting and lining up the holes in the pole with those in the fitting. Place a pin in the first hole to secure the pole in place.
3. Attach the hip rafter (14'4" red) to the remaining points of the Half Crown using the same technique as in step 2.
4. Attach a spreader (9'4" white) to the Half Crown, and connect it to the Spreader T. Attach another spreader (9'4" white) from the Spreader T to the second Spreader T and repeat for a total of 3 Spreader T's. The last Spreader T will connect to the second Half Crown. Attach rafters (21'10" orange) to the Spreader T's. Repeat steps 2 & 3.
5. Attach the Bear Claw fitting to the 4 hip poles (14'4" red) by sliding the pole over the fitting. Line up the hole of the pole with those of the fitting and place a pin. Attach hip rafters (14'4" red) to the Bear Claw fitting at points 1, 3, and 5.
6. Attach corner poles (10'6" green) to the Bear Claw fitting at points 2 and 4.
7. Attach the corner fitting to the hip rafter (point 3 only) by sliding the pole over the fitting. Line up the hole of the pole with those of the fitting and place a pin. Attach the Fan T's to the rafters (21'10" orange) and to the hip rafters (points 1 & 5).

8. Join the Regular T fittings to the corner poles (10'6" green) by sliding the pole over the fitting. Line up the hole of the pole with those of the fittings and place a pin.

9. The perimeter is ready for assembly. Connect the Regular T's to the corners and Fan T's using the spreaders (9'4" white). Slide the poles over the fittings, line up the holes, and pin the pole and fitting together. When all of the spreaders have been secured in place, the frame will be complete.

NOTE . The tent top now needs to be laced together. It is best to do this on the ground along the length of the frame if space permits. The tent can be laced together while over the frame, but is more difficult and time consuming.

10. Lace the tent together: A) Line up the two crown patches in the middle of the tent section (the lace end will always be on the bottom). Starting in the middle and working out, B) Pull the first lace up through the first small grommet. C) Pull the second lace through the second grommet. D) Pull the second lace through the first lace's loop. E) Pull the third lace through third grommet. F) Pull the third lace through the second lace's loop.

Repeat steps B through F down the lace line of the tent until the third grommet from the edge of the tent is reached, the third lace should be twice as long as all of the other loops (referred to as double loop). When the tent is laced down to the third grommet (the double loop), pull the remaining 2 laces through the remaining 2 grommets. Loop the second lace from the tent perimeter into the first lace (the lace is now going towards the direction of the double loop). Pull the third lace (double loop) through the second loop. The third lace (double loop) should now be strung through 2 loops (the second loop and the fourth loop). Tie-off the double loop with the fourth lace so the loops can not come loose. Note: This does not in anyway affect the strength of the tent; it holds the tent sections together. A simple double knot is effective. After lacing each section, you will need to fasten down the rain flap that covers the lace line by clipping the spring clips onto the rain flap closer rope.

11. Place the tent top over the frame, by spreading the tent out on the 60' end and flapping the tent top while pulling it over the top. This, flapping, will make it easier to go over the frame and prevents any snags.

12. Secure the tent top to the frame by fastening the straps on the inside of the tent at each corner location.

13. Start at one corner and manually lift the frame so that the leg (7'8" black) can slide over the corner fitting. Pin the leg to the fitting. (When raising the tent, raise INTO the wind)

14. Proceed to work your way around the tent putting one leg in at a time until all legs are standing and pinned.

15. Now that the frame tent is erected, fasten the rest of tent top completely to the frame, using the straps on the inside of the tent. Make sure that all of the straps are tight and that the tent top is sitting evenly over the frame.

16. Drive a stake about four feet out from each leg and tie off the rope or ratchet to each leg.

Your tent installation is now complete.

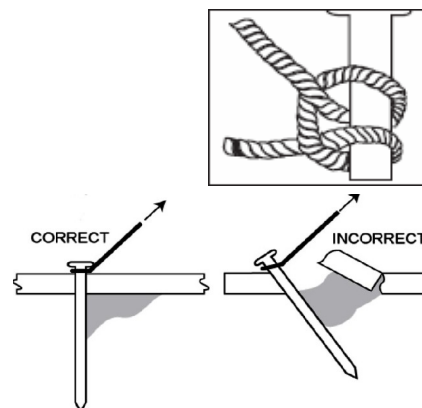

All Seasons Tent Sales

40 x 100 Frame Tent Set Up Instructions

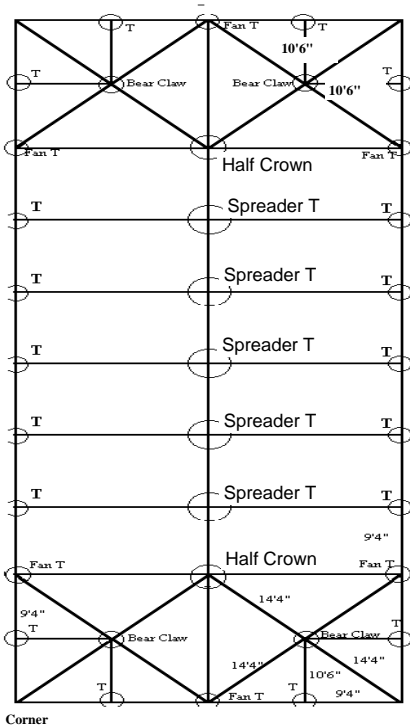

Pipe			
QTY	SIZE	COLOR	Style
16	21'10"	Orange	Rafter
16	14'4"	Red	Hip Rafter
8	10'6"	Green	Corner Rafter
34	9'4"	White	Spreader
28	7'8"	Black	Legs

Components	
QTY	Style
2	Half Crowns
4	Regular Corners
18	Regular T's
5	Spreader T
4	Bear Claws
6	Fan T
28	Weights / Stakes
28	Ropes
180	Tent Pins
Optional Items	
1	Brace Package
4	Spreader Cables
28	Ratchets
28	Baseplates

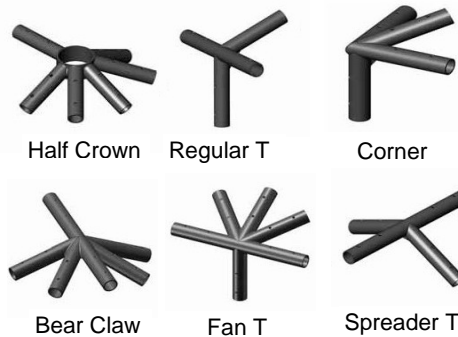

Pre-Site Inspection- Call your local utility companies prior to installation for any underground obstructions.

1. Layout the frame parts in the estimated location pertaining to the diagram. The spreader pipe is placed out to form the perimeter, and the rafters are laid in the interior location.
2. Start with one of the Half Crowns. Attach the poles (21'10" orange) to the Half Crown at points 1, 3, & 5 by sliding the pole over the fitting and lining up the holes in the pole with those in the fitting. Place a pin in the first hole to secure the pole in place.
3. Attach the hip rafter (14'4" red) to the remaining points of the Half Crown using the same technique as in step 2.
4. Attach a spreader (9'4" white) to the Half Crown, and connect it to the Spreader T. Attach another spreader (9'4" white) from the Spreader T to the second Spreader T and repeat for a total of 5 Spreader T's. The last Spreader T will connect to the second Half Crown. Attach rafters (21'10" orange) to the Spreader T's. Repeat steps 2 & 3.
5. Attach the Bear Claw fitting to the 4 hip poles (14'4" red) by sliding the pole over the fitting. Line up the hole of the pole with those of the fitting and place a pin. Attach hip rafters (14'4" red) to the Bear Claw fitting at points 1, 3, and 5.
6. Attach corner poles (10'6" green) to the Bear Claw fitting at points 2 and 4.
7. Attach the corner fitting to the hip rafter (point 3 only) by sliding the pole over the fitting. Line up the hole of the pole with those of the fitting and place a pin. Attach the Fan T's to the rafters (21'10" orange) and to the hip rafters (points 1 & 5).

8. Join the Regular T fittings to the corner poles (10'6" green) by sliding the pole over the fitting. Line up the hole of the pole with those of the fittings and place a pin.

9. The perimeter is ready for assembly. Connect the Regular T's to the corners and Fan T's using the spreaders (9'4" white). Slide the poles over the fittings, line up the holes, and pin the pole and fitting together. When all of the spreaders have been secured in place, the frame will be complete.

NOTE . The tent top now needs to be laced together. It is best to do this on the ground along the length of the frame if space permits. The tent can be laced together while over the frame, but is more difficult and time consuming.

10. Lace the tent together: A) Line up the two crown patches in the middle of the tent section (the lace end will always be on the bottom). Starting in the middle and working out, B) Pull the first lace up through the first small grommet. C) Pull the second lace through the second grommet. D) Pull the second lace through the first lace's loop. E) Pull the third lace through third grommet. F) Pull the third lace through the second lace's loop.

Repeat steps B through F down the lace line of the tent until the third grommet from the edge of the tent is reached, the third lace should be twice as long as all of the other loops (referred to as double loop). When the tent is laced down to the third grommet (the double loop), pull the remaining 2 laces through the remaining 2 grommets. Loop the second lace from the tent perimeter into the first lace (the lace is now going towards the direction of the double loop). Pull the third lace (double loop) through the second loop. The third lace (double loop) should now be strung through 2 loops (the second loop and the fourth loop). Tie-off the double loop with the fourth lace so the loops can not come loose. Note: This does not in anyway affect the strength of the tent; it holds the tent sections together. A simple double knot is effective. After lacing each section, you will need to fasten down the rain flap that covers the lace line by clipping the spring clips onto the rain flap closer rope.

11. Place the tent top over the frame, by spreading the tent out on the 60' end and flapping the tent top while pulling it over the top. This, flapping, will make it easier to go over the frame and prevents any snags.

12. Secure the tent top to the frame by fastening the straps on the inside of the tent at each corner location.

13. Start at one corner and manually lift the frame so that the leg (7'8" black) can slide over the corner fitting. Pin the leg to the fitting. (When raising the tent, raise INTO the wind)

14. Proceed to work your way around the tent putting one leg in at a time until all legs are standing and pinned.

15. Now that the frame tent is erected, fasten the rest of tent top completely to the frame, using the straps on the inside of the tent. Make sure that all of the straps are tight and that the tent top is sitting evenly over the frame.

16. Drive a stake about four feet out from each leg and tie off the rope or ratchet to each leg.

Your tent installation is now complete.

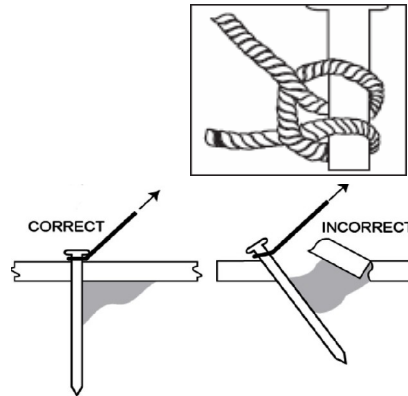

This document was created with Win2PDF available at <http://www.win2pdf.com>.
The unregistered version of Win2PDF is for evaluation or non-commercial use only.
This page will not be added after purchasing Win2PDF.