

# All Seasons Tent Sales

## 40 x 100 All Trac Frame Tent Set Up Instructions

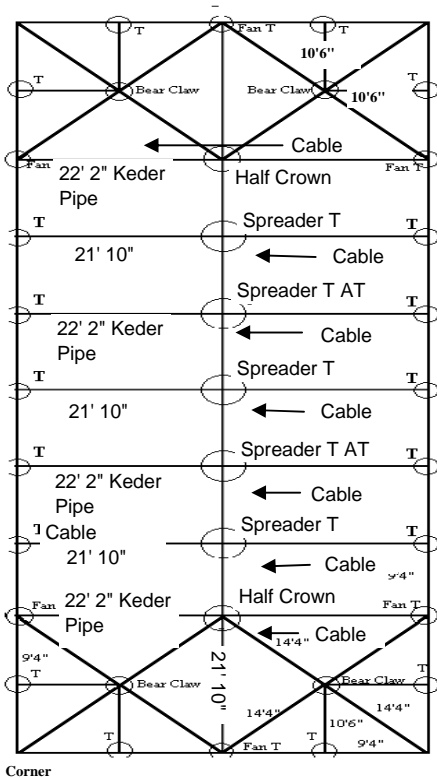

Pipe			
QTY	SIZE	COLOR	Style
8	22' 2"	Orange	Keder
8	21' 10"	Orange	Rafter
16	14' 4"	Red	Hip Rafter
8	10' 6"	Green	Corner Rafter
34	9' 4"	White	Spreader
28	7' 8"	Black	Legs

Components	
QTY	Style
2	Half Crowns
4	Regular Corners
18	Regular T's
3	Spreader T
2	Spreader T - AT
4	Bear Claws
6	Fan T
28	Ratchets
28	Baseplates
28	Weights / Stakes
180	Tent Pins
7	Spreader Cables
Optional Items	
1	Brace Package

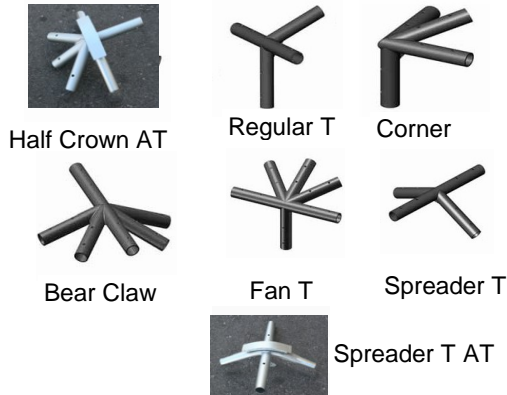

Pre-Site Inspection- Call your local utility companies prior to installation for any underground obstructions.

1. Layout the frame parts in the estimated location pertaining to the diagram. The spreader pipe is placed out to form the perimeter, and the rafters are laid in the interior location.
2. Start with one of the Half Crowns. Attach the hip rafters (21' 10" orange) to the Half Crown at the third point, and attach the Keder pipe to the one and five points. Place a pin in the first hole to secure the pole in place.
3. Attach the hip rafter (14' 4" red) to the remaining points of the Half Crown using the same technique as in step 2.
4. Attach a spreader (9' 4" white) to the Half Crown, and connect it to the Spreader T. Attach another spreader (9' 4" white) from the Spreader T to the Spreader T- AT and repeat for a total of 5 Spreader T's. The last Spreader T will connect to the second Half Crown. Attach rafters (21' 10" orange) to the Spreader T's one and three. Attach the keder pipe to the second and fourth spreader T - AT's.
5. Attach the Bear Claw fitting to the 4 hip poles (14' 4" red) by sliding the pole over the fitting. Line up the hole of the pole with those of the fitting and place a pin. Attach hip rafters (14' 4" red) to the Bear Claw fitting at points 1, 3, and 5.
6. Attach corner poles (10' 6" green) to the Bear Claw fitting at points 2 and 4.
7. Attach the corner fitting to the hip rafter (point 3 only) by sliding the pole over the fitting. Line up the hole of the pole with those of the fitting and place a pin. Attach the Fan T's to the rafters (21' 10" orange) and to the hip rafters (points 1 & 5).

8. Join the Regular T fittings to the corner poles (10'6" green) by sliding the pole over the fitting. Line up the hole of the pole with those of the fittings and place a pin.

9. The perimeter is ready for assembly. Connect the Regular T's to the corners and Fan T's using the spreaders (9'4" white). Slide the poles over the fittings, line up the holes, and pin the pole and fitting together. Attach the 7 cables along the 100ft side. 5 along the center regular T's, And 2 near the Fan T's. Slide cable over the perimeter White 9'4" before pinning the pipe to the fittings. **NOTE - Failure to attach cable could cause tent to collapse when raising.**

When all of the spreaders have been secured in place, the frame will be complete.

10. Slide the keder on the tent through the keder pipe starting at the regular t going up through the Half Crown, then come back down the other side. Then slide the middle tent top pieces through the middles. Repeat the step for the other end tent top section.

11. Secure the tent top to the frame by fastening the straps on the inside of the tent at each corner location.

12. Start at one corner and manually lift the frame so that the leg (7'8" black) can slide over the corner fitting. Pin the leg to the fitting. ( When raising the tent, raise INTO the wind)

13. Proceed to work your way around the tent putting one leg in at a time until all legs are standing and pinned. Put baseplate under legs and attach 1" ratchets from the "O" rings at the ends of the valance to the baseplates. Tighten loosely.

14. Now that the frame tent is erected, fasten the rest of tent top completely to the frame, using the straps on the inside of the tent. Evenly tighten the ratchets straps on the corners. Make sure the rope through the valance slides smoothly. Make sure that all of the straps are tight and that the tent top is sitting evenly over the frame. Evenly tighten the ratchets straps on the corners. Make sure the rope through the valance slides smoothly.

15. Drive a stake about four feet out from each leg and tie off the rope or ratchet to each leg.

Your tent installation is now complete.

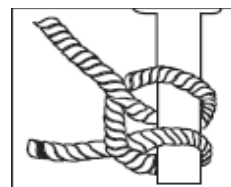
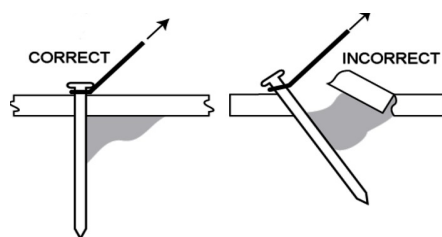

This document was created with Win2PDF available at <http://www.win2pdf.com>.  
The unregistered version of Win2PDF is for evaluation or non-commercial use only.  
This page will not be added after purchasing Win2PDF.